

HPA Air Blower

High Quality Portable Air Transfer Fans

hydor



The Hydor HPA Portable Air Blower offers excellent air flow and pressure capabilities, and is designed specifically to provide temporary or permanent ventilation for a wide variety of commercial and industrial applications such as equipment enclosures, infrastructure pits, tunnels, construction areas, welding operations, vessel purging etc.

This compact, powerful fan delivers up to 1.25m³/s of air and pressure up to 350Pa.

Features & Accessories

- High performance axial-flow impeller design.
- Durable rolled sheet steel casing with epoxy paint finish.
- Plastic handle for easy carrying.
- Robust OH&S approved safety guards.
- High performance induction motor, IP44 protection with built-in thermal cut-out protection.
- Tested and approved to comply with Australian and New Zealand electrical safety requirements.
- Sealed for life bearings, can operate at any angle.
- Suitable for operating temperatures up to 60°C.

Optional Flexible Duct

- PVC fire retardant with operation up to 150°C.
- 300mm dia to suit fan, supplied in 5m lengths.
- Can be connected to make longer lengths.



HPA Air Blower

High Quality Portable Air Transfer Fans

hydor

Performance & Electrical Data

Product Code	Nominal Dia. mm	Speed RPM	Airflow m ³ /s	Pressure Pa	Motor Electrical Data		Sound Level dB(A) @ 1m	Weight Kg
					Volts/Hz	Power Watts		
HPA300	300	2900	1.25	350	240 / 50	550	92	17

Dimensional Data

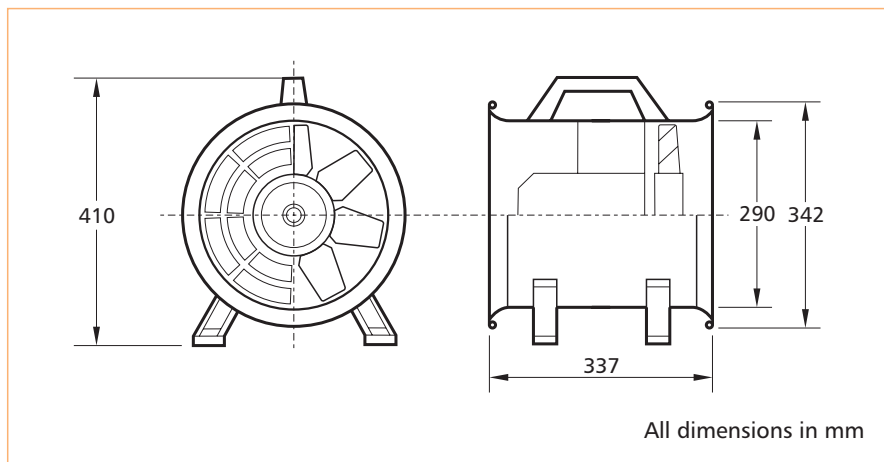

Optional Flexible Duct



Product Code: **HPA300-FD5**
Length: 5m x 300mm dia.
Material: Fire retardant PVC.
Max exposure temp: 150°C

Contact Us

Mail: P.O. Box 1075, Mt. Waverley 3149, Victoria, Australia
Phone: 1300 655 730
Fax: 1300 134 319
Email: info@hydor.com.au
Web: www.hydor.com.au

hydor

For sales enquiries call:-