

HV Fan Range

High Efficiency Belt Drive Fans

hydor



The Hydor HV fan includes six self-cleaning blades, a mesh safety guard on either side of the unit and a durable galvanised steel fan housing. It also features heavy duty shutters (on shutter models only) that helps to reduce heat loss.

Ideally suited for ventilation applications requiring large volumes of air with low noise and fan speed. These include agricultural applications such as poultry sheds and greenhouses as well as large workshops, warehouses and recreation halls.

Features Include

- Available in 800mm, 1000mm & 1250mm propeller aperture diameter
- Quality robust construction incorporating stainless steel propeller
- Single or three phase motors
- Speed-controllable using electronic, auto-transformer or inverter controllers
- Efficient, reliable, high volume air movement.
- Automatic outlet louvre shutter
- Options for corrosion resistant nylon inlet guard (for poultry applications) or expanded metal guards (for general industrial or agricultural applications)



Industrial, Agricultural, Horticultural and Domestic Ventilation

HV Fan Range

High Efficiency Belt Drive Fans

Technical Data

Product Code	Style	Motor Speed RPM	Impeller Speed RPM	Motor Electrical Data 220-240V / Single Phase / 50Hz		Motor Electrical Data 415V / Three Phase / 50Hz		Airflow m ³ /s @ Static Pressure Pa.		Sound Level dB(A) @3m
				FL Amps	Output kW	FL Amps	Output kW	0	25	
HV80(M/T)75L	With shutters	1400	630	2.6	0.55	1.5	0.55	5.00	4.47	75
HV100(M/T)100L	With shutters	1440	503	3.5	0.75	2.0	0.75	8.89	6.94	76
HV125(M/T)150L	With shutters	1400	485	4.8	1.1	2.8	1.1	11.95	10.41	78
HV80(M/T)75P	No shutters	1400	630	2.6	0.55	1.5	0.55	5.00	4.47	75
HV100(M/T)100P	No shutters	1400	503	3.5	0.75	2.0	0.75	8.89	6.94	76
HV125(M/T)150P	No shutters	1400	485	4.8	1.1	2.8	1.1	11.95	10.41	78

M = Single Phase, 240V, T = Three Phase, 415V

Dimensional Data

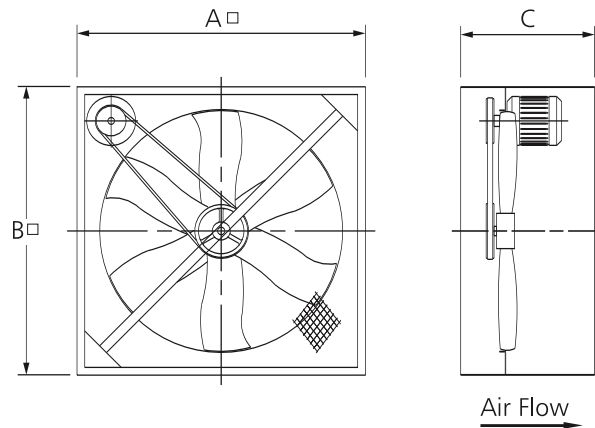

Product Code	Width (A)	Height (B)	Depth (C)		Weight Kg	
			With Shutters	No Shutters	With Shutters	No Shutters
HV80..	925	925	427	383	49	42
HV100..	1125	1125	447	383	64	58
HV125..	1375	1375	480	416	90	80

All dimensions in mm

Contact Us

Address: 42 - 62 Pound Road West,
Dandenong South, Victoria, 3175, Australia.

Phone: 1300 655 730

Fax: 1300 134 319

Email: info@hydor.com.au

Web: www.hydor.com.au



For sales enquiries call:-

Hydor reserves the right to make changes in design or specification to products without notice or obligation and to change or discontinue models.