

# Header Box Ceiling Fan

Efficiently clears steam and odours

# hydor

The Hydor HDC range of quality, ceiling mounted, header box fans, has been designed to clear rooms of steam and reduce the build-up of unpleasant odours.

They are suitable for a range of domestic applications including toilets, bathrooms, kitchens and laundries, and can be easily installed into the ceiling by one person. The HDC fan features a high performance centrifugal impeller that produces powerful air flow and low noise.

Both HDC models include an integral non-return damper that eliminates backdraft from the outside elements.

## Features Include

- Made from durable injection moulded plastic
- Removable clip-in grille makes cleaning easy
- Convenient installation with ceiling latch or screw-in fixing
- Efficient fan design provides quiet smooth operation
- High performance "continuous run" motor
- Built-in thermal overload protection
- Non-return damper eliminates backdraft
- 6 minute run-on timer version available
- Certificate of Approval number: Q070225

Industrial, Agricultural, Horticultural and Domestic Ventilation

# Header Box Ceiling Fan

Efficiently clears steam and odours

## Technical Data

Product Code	Speed RPM	Power W	Volts/ Hz	Sound Level dB(A) @3m	Fitted with Run-on Timer	Weight kg
HDC100A	1365	30	240/50	33	No	2.5
HDC150	1050	35	240/50	35	No	3.25
HDC100AT	1365	30	240/50	33	Yes	2.5
HDC150T	1050	35	240/50	35	Yes	3.25

Standard model has a plug and lead fitted.  
Run-on timer model requires direct wire with switch and constant active wires.

## Performance Curve

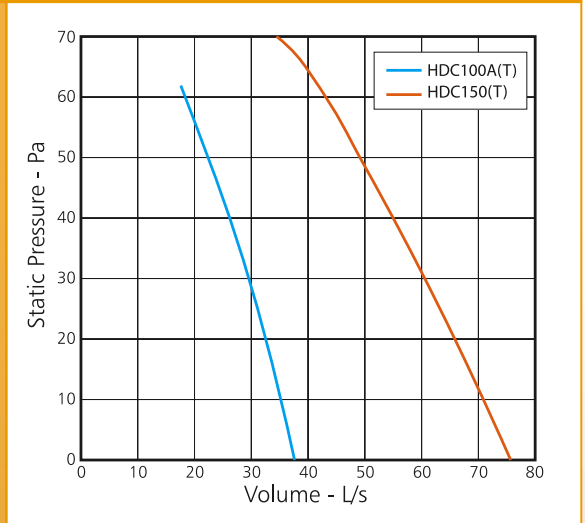

## Dimensional Data

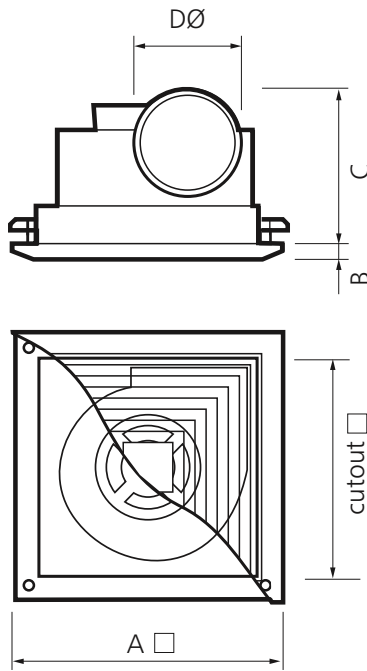

Product Code	Cut-out □	A □	B	C	D Ø
HDC100A(T)	232	267	20	168	100
HDC150(T)	278	322	22	192	150

All dimensions in mm

## Typical Installation

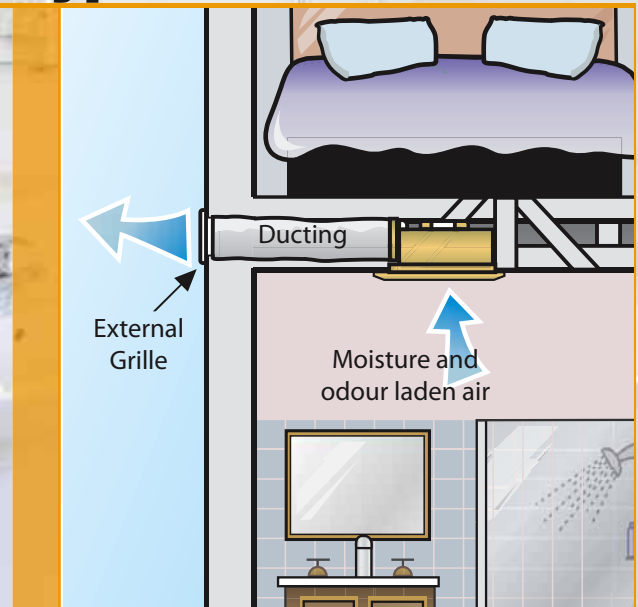

## Contact Us

Address: 42 - 62 Pound Road West,  
Dandenong South, Victoria, 3175, Australia.  
Phone: 1300 655 730  
Fax: 1300 134 319  
Email: [info@hydor.com.au](mailto:info@hydor.com.au)  
Web: [www.hydor.com.au](http://www.hydor.com.au)



For sales enquiries call:-