

Tornado Fan

Provides fast cool relief

hydor



Hydor Tornado portable cooling fans provide quiet operation and a powerful, uniform distribution of air. Available in two sizes – 300mm and 500mm – the fans feature three speed settings, an adjustable lock in vertical tilt mechanism and a sturdy chrome finished tube frame.

The versatile Tornado fans are suitable for a wide range of commercial, industrial, agricultural and domestic applications including assembly cells, workshops, gymnasiums and outdoor living areas.

Each fan comes with a mounting bracket which allows it to be fixed to a wall and a carry handle so it can be easily moved to other areas.

The fans are approved to Australian and New Zealand standards. (Q090140)

Features Include

- 3-speed push button control for convenient air adjustment
- Durable chrome plated tube frame and grille
- Adjustable airflow direction via locking knobs
- Rubber feet to minimise floor movement
- Carry handle for easy transport
- 1.8 metre long power lead
- Sealed-for-life ball bearings in motor
- Certificate of approval number: Q090140
- Wall mountable



Industrial, Agricultural, Horticultural and Domestic Ventilation

Tornado Fan

Provides fast cool relief

Specifications

Model	Volt V	First Speed				Second Speed				Third Speed			
		Amps A	Watts W	Noise dB	Speed RPM	Amps A	Watts W	Noise dB	Speed RPM	Amps A	Watts W	Noise dB	Speed RPM
HVF-30	230-240V	0.15	35	44	1140	0.17	40	46	1230	0.21	50	49	1330
HVF-50	230-240V	0.58	140	58	1180	0.63	150	60	1280	0.67	160	62	1380

Dimensional Data

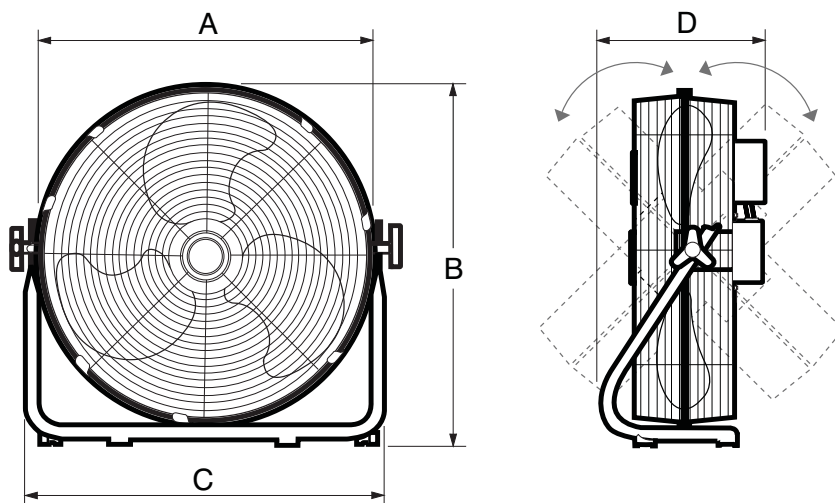

Model	A	B	C	D
HVF-30	360	390	370	183
HVF-50	550	605	600	220

Dimensions in mm



Tornado fan fixed to wall using supplied mounting bracket



3-speed push button control

Contact Us

Address: 42 - 62 Pound Road West,
Dandenong South, Victoria, 3175, Australia.

Phone: 1300 655 730

Fax: 1300 134 319

Email: info@hydor.com.au

Web: www.hydor.com.au

For sales enquiries call:-